



2019 COLLECTION



LIGHTING & DETAILS

Eclectic



CONSIGLIO / ADVICE

I prodotti possono presentare piccole variazioni e imperfezioni dovute alla artigianalità della lavorazione del materiale e rendono ogni manufatto unico.

Le finiture ottone e nichel sono volutamente al naturale e quindi soggette a cambiamenti e opacizzazioni che donano all'oggetto bellezza e patinatura del tempo.

Qualora si voglia evitare queste alterazioni, su richiesta possiamo verniciare i manufatti, con finitura semilucida o opaca.

The products may show small variations and imperfections due to the craftsmanship of the work of the material and make unique each piece.

The brass and nikel finishings are intentionally natural and so are subject to variations and opacifications that give the object beauty and patina of time.

If you wish to avoid these modifications, it is possible to ask us for a semishiny or matte varnishing.

ROSA CANINA / 8

GINGKO BILOBA / 14

QUERCIA / 18

BAMBOO / 24

HORN / 30

FAUNA / 34

CARRUBO / 40

DISEGNI TECNICI, FINITURE & COLORI

(TECHNICAL DESIGNS, FINISHINGS AND COLOURS) / 44

BOTTEGA



Brass Brothers & co.® è un nuovo e giovane brand di illuminazione e complementi di arredo, nato all'interno de Il Bronzetto®, azienda attiva dal 1963 a Firenze. Brass Brothers & co.® è un progetto di idee condivise da un gruppo di artigiani, designers e creativi. Le linee proposte coniugano un rinnovato design e uso dei materiali al ricordo e saper fare del secolo scorso. Nasce così una linea contemporanea dal gusto vintage, attenta alla qualità, in cui artigianalità e progettualità coesistono. Realizziamo da sempre prototipi su commissione per soddisfare le richieste specifiche dei nostri clienti. Per questo possiamo affermare che passato e futuro si fondono nelle nostre sapienti mani. La produzione proposta da Brass Brothers & co.® è interamente pensata e lavorata a Firenze e suoi dintorni.

Brass Brothers & co.® is a new young brand of lightings and furnishings, born inside Il Bronzetto® company, active in Florence since 1963. Brass Brothers & co.® is a project of ideas shared by a group of artisans, designers and creatives. The proposed products combine a renewed design and a new use of materials with the memory and the knowledges of last century. The result is a contemporary line of items with a vintage mood, attentive to the quality, in which craftsmanship and project coexist. We have always realized commissioned prototypes to meet the specific requirements of our customers. For this reason, we can say that the past and future melt in our expert hands. Brass Brothers & co.® manufacture is entirely made in Florence and its surroundings.

Eclectic



IL TEAM



eclectic

Lampade, tavoli e pomelli della collezione **Eclectic** attingono da elementi della flora e fauna terrestre per creare nuovi stili e forme dal gusto eccentrico. Talvolta elementi delle profondità marine e multiformi fronde di vari tipi di alberi, vengono immortalati nelle nostre fusioni mantenendo eterna la loro matericità, altre volte invece la natura fa da musa alla nascita di curiose forme ad essa ispirate. L'ottone è lavorato in modo da creare superfici irregolari dalle finiture non uniformi che rendono l'imperfetta unicità degli elementi naturali.

Lightings, tables and knobs of the EclecticCollection draw from real flora and fauna elements to create new styles and shapes with an excentric taste. At times elements from the sea-depths or branches taken from various trees, are forever captured in our fusions which keep their true essence intact. Other times nature simply acts as a muse to allow the creation of shapes which from it draw their inspiration. Brass is crafted and procesed so as to create irregular surfaces with uneven finishes which best recreate the imperfect uniqueness of nature.

ROSA CANINA



TAVOLINO PICCOLO/GRANDE
SIDE TABLE SMALL/LARGE

ROS 01 S/M

PIANTANA
FLOOR LAMP

ROS 02



LAMPADA DA TAVOLO GRANDE
MEDIUM TABLE LAMP

ROS 03 M



LAMPADA DA TAVOLO PICCOLA
SMALL TABLE LAMP SMALL

ROS 03 S



ROSA CANINA

pg 12



TAVOLO
TABLE
ROS 04



TAVOLO
TABLE
ROS 05

dettagli a pg 46 | details on pg 46





GINGKO
BILOBA



TAVOLO BISTROT
BISTROTTABLE
GIN 01



TAVOLINO
SIDE TABLE
GIN 02



APPLIQUE SINGOLA
WALL LIGHT
GIN 05



APPLIQUE PICCOLA
SMALL WALL LIGHT
GIN 04



APPLIQUE GRANDE
LARGE WALL LIGHT
GIN 03

QUERCIA



QUERCIA

pg 20



APPLIQUE QUERCIA
OAK WALL LAMP

OAK 04

dettagli a pg 48 | details on pg 48

QUERCIA

pg 21



TAVOLINO VETRO
GLASS SIDE TABLE

OAK 01

dettagli a pg 48 | details on pg 48

Limited Edition



TAVOLINO AGATA
AGATE SIDE TABLE

OAK 01 A



TAVOLINO LEGNO FOSSILE
PETRIFIED WOOD SIDE TABLE

OAK 01 B



TAVOLINO LEGNO FOSSILE
PETRIFIED WOOD SIDE TABLE

OAK 01 C



BAMBOO

BAMBOO

pg 26



PIANTANA
FLOOR LAMP

BAM 01



LAMPADA DA TAVOLO
TABLE LAMP

BAM 02

BAMBOO

pg 27



TAVOLO PICCOLO
TABLE SMALL
BAM 03 S



TAVOLO GRANDE
TABLE LARGE
BAM 03 L



TAVOLO MEDIO
TABLE MEDIUM
BAM 03 M

BAMBOO

pg 28



TRIS TAVOLI
TRIO TABLES
BAM 04

TAVOLO OTTAGONALE
OCTOGONAL TABLE
BAM 05



dettagli a pg 49 e 50 | details on pg 49 and 50

BAMBOO

pg 29



ETAGERE
SHELF RACK
BAM 07

TAVOLO
TABLE
BAM 06



dettagli a pg 50 | details on pg 50



HORN



TAVOLO
TABLE
HOR 01



APPLIQUE CORNO
HORN WALL LAMP
HOR 02



LAMPADA DA TAVOLO
TABLE LAMP
HOR 3



LAMPADA DA TAVOLO
TABLE LAMP
HOR 4



FAUNA

Eclectic



APPLIQUE SERPENTE
SNAKE WALL LIGHT

BES 01



APPLIQUE CIVETTA
OWL WALL LIGHT

BES 02



APPLIQUE TARTARUGA
TURTLE WALL LIGHT

BES 03



LAMPADA DA TAVOLO TARTARUGA
TURTLE TABLE LAMP

BES 04



LAMPADA DA TAVOLO
TABLE LAMP

BES 05A



LAMPADA DA TAVOLO
TABLE LAMP

BES 05B



CARRUBO



LAMPADARIO
CHANDELIER

CAR 01



APPLIQUE
WALL LAMP

CAR 02

DISEGNI
TECNICI,
RIFINITURE &
COLORI
TECHNICAL
DESIGNS,
FINISHINGS AND
COLOURS

ROSA CANINA

pg 46

ROS 01 S

(pg. 10)

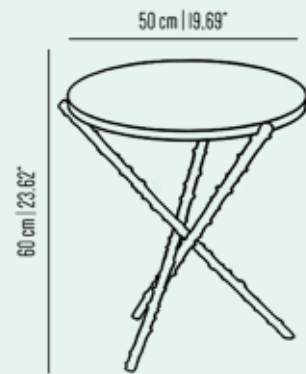

ROS 01 M

(pg. 10)



ROS 02

(pg. 11)

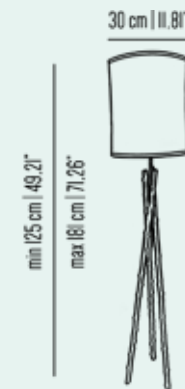

ROS 03 S

(pg. 10)

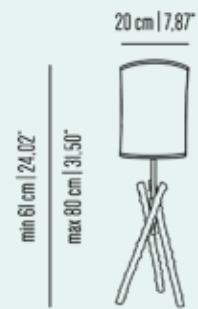

ROS 03 M

(pg. 11)

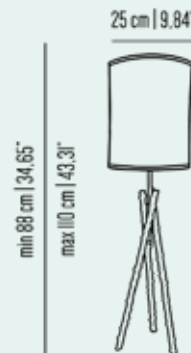

ROS 04

(pg. 12)

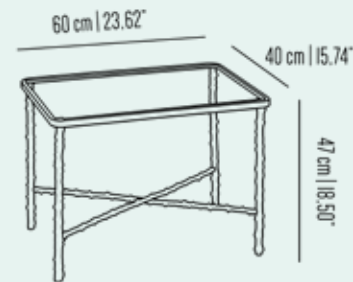

ROS 04

(pg. 12)

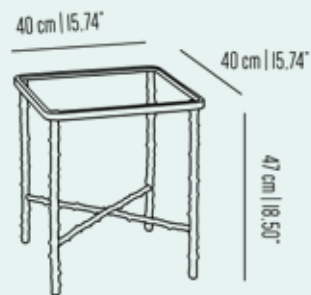

GIN 01

(pg. 16)

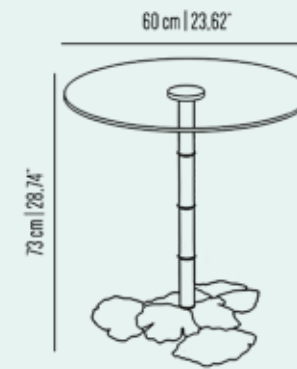

GIN 02

(pg. 16)

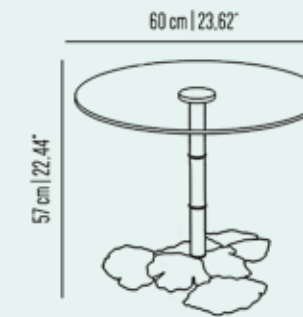

GIN 03

(pg. 17)

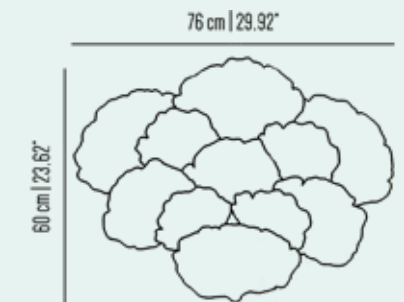

GIN 04

(pg. 17)



GIN 05

(pg. 17)



• FINITURE STRUTTURA ESTENDIBILE IN OTTONE BRASS ADJUSTABLE STRUCTURE FINISHING



• PIANO

TOP

Vetro trasparente | Clear glass

• PARALUME

SHADE

Cotone grezzo solar crema | Cream unbleached cotton

PORTALAMPADA LAMPHOLDER

1 x G9 max 18 W (GIN05)
3 x G9 max 18 W (GIN04)
4 x G9 max 18 W (GIN03)

• FINITURE STRUTTURA IN OTTONE BRASS COLOUR FINISHING:



• PIANO

TOP

Vetro trasparente | Clear glass

PORTALAMPADA LAMPHOLDER

1 x E27 max 75 W

QUERCIA

pg 48

OAK 04
(pg. 20)

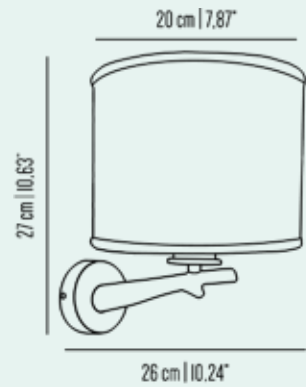

OAK 01
(pg. 21)

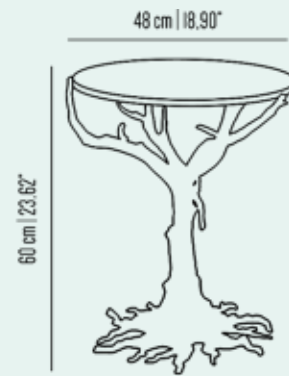

OAK 01 A
(pg. 22)

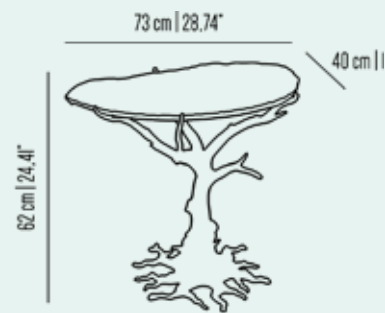

OAK 01 B + C
(pg. 22/23)

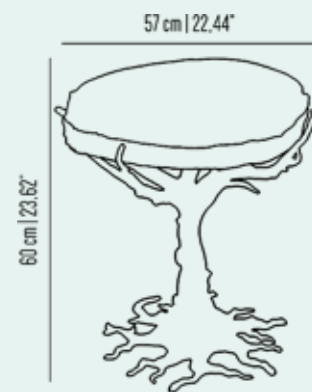

BAMBOO

pg 49

BAM 01
(pg. 26)

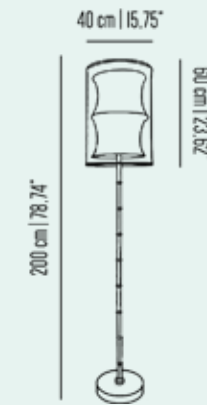

BAM 02
(pg. 26)

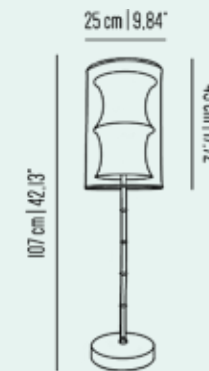

BAM 03 S
(pg. 27)



BAM 03 M
(pg. 27)



BAM 03 L
(pg. 27)

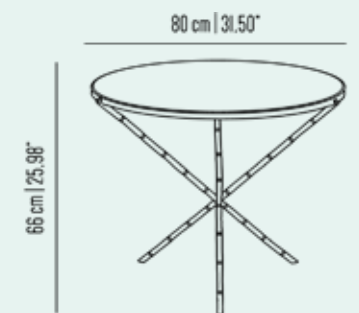

BAM 04
(pg. 28)

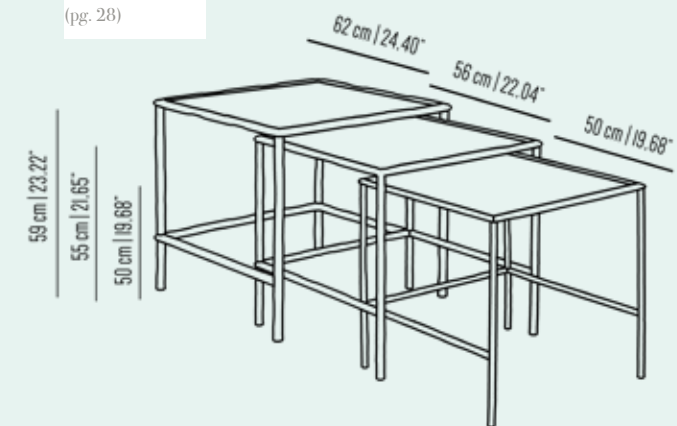

- **FINITURE STRUTTURA IN OTTONE**
BRASS COLOUR FINISHING



- **PIANO**
TOP
Vetro trasparente | Clear glass
Pezzi unici di legno fossile | Pieces of petrified wood
Agata | Agate
- **PARALUME**
SHADE
Iuta

PORTALAMPADA
LAMPHOLDER
1 x E27 max 75 W

BAMBOO

pg 50

BAM 05
(pg. 28)

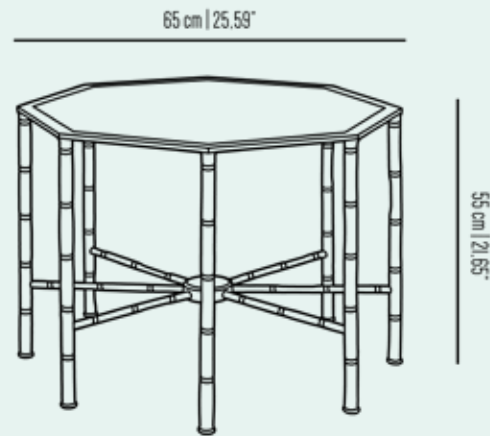

BAM 06
(pg. 29)

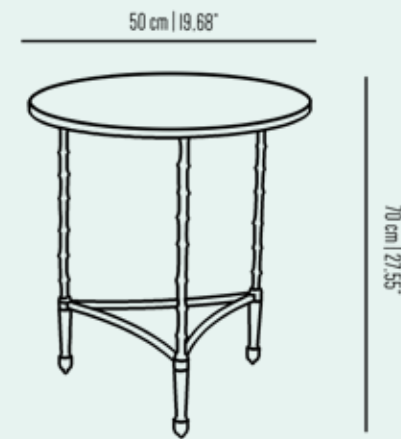

BAM 07
(pg. 29)



• **FINITURE STRUTTURA IN OTTONE**
BRASS COLOUR FINISHING



• **PARALUME**
SHADE

Lino naturale esterno | Natural linen outside
Cotone bianco interno | White cotton inside

• **BASE MARMO**
MARBLE BASE



PORTALAMPADA
LAMPHOLDER

2 x E27 max 75 W (BAM01)
1 x E27 max 75 W (BAM02)

HORN

pg 51

HOR 01
(pg. 32)

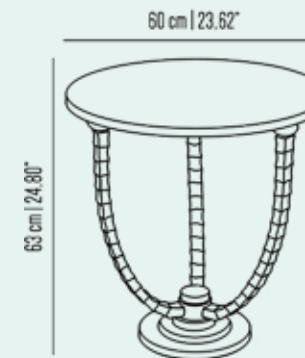

HOR 03
(pg. 33)

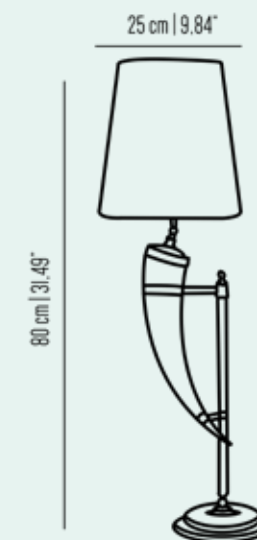

HOR 02
(pg. 32)

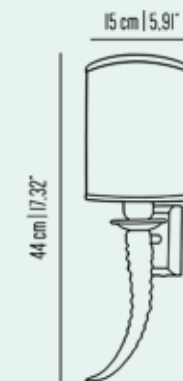

HOR 04
(pg. 33)



• **FINITURE STRUTTURA IN OTTONE**
BRASS COLOUR FINISHING



• **PARALUME**
SHADE

Iuta

• **BASE MARMO**
MARBLE BASE



PORTALAMPADA
LAMPHOLDER

1 x E27 max 75 W

FAUNA

pg 52

BES 01
(pg. 36)

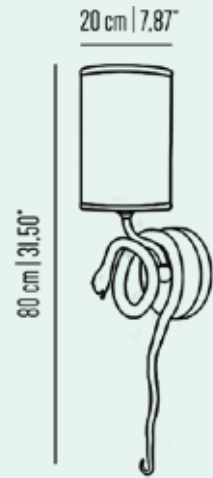

BES 04
(pg. 38)

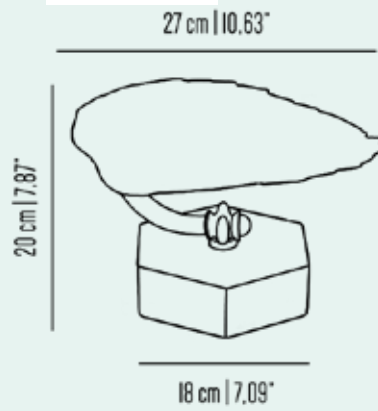

BES 03
(pg. 37)

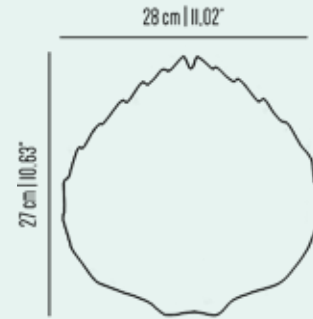

BES 05 B
(pg. 39)

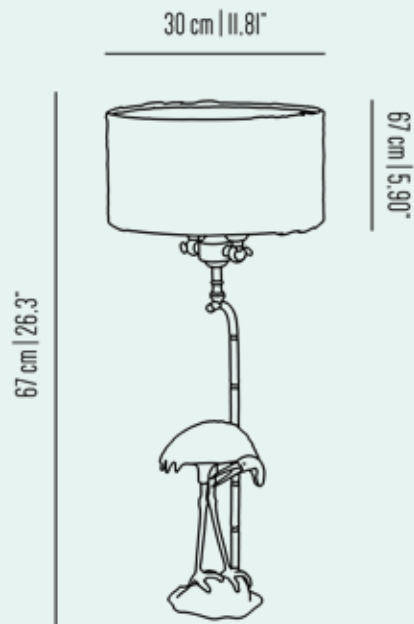

BES 05 A
(pg. 39)

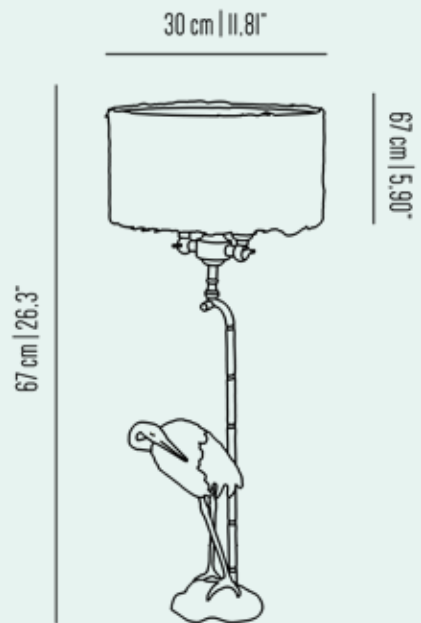

BES 02
(pg. 37)



- **FINITURE STRUTTURA IN OTTONE**
BRASS COLOUR FINISHING



- **PARALUME**
SHADE
Pvc lucido nero | Black glossy pvc (BES01)
Alluminium (BES02)

- **BASE MARMO**
MARBLE BASE
Marmo nero marquina
Marmo bianco di Carrara
Marmo marrone Emperador

PORTALAMPADA
LAMPHOLDER
1 x E27 max 75 W (BES01), 2 x C9 max 18 W (BES02), 1 x C9 max 18 W (BES03 and BES04)

CARRUBO

pg 53

CAR 01
(pg. 42)

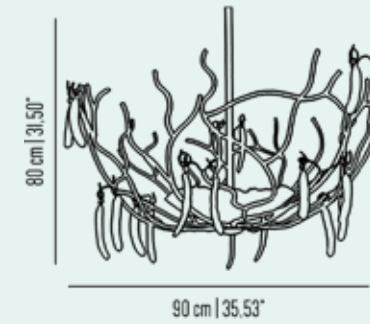

CAR 02
(pg. 43)

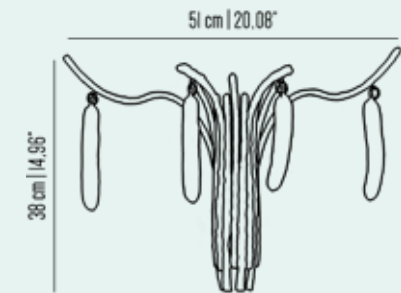

PORTALAMPADA
LAMPHOLDER
6 x C9 max 18 W (CAR01)
1 x E27 max 75 W (CAR02 and CAR03)

- **FINITURE STRUTTURA IN OTTONE**
BRASS COLOUR FINISHING





The background is a vibrant, tropical-themed illustration. It features a large pink flamingo in the center, surrounded by various tropical plants like bird of paradise flowers, blue plumeria, and a butterfly. Several lamps are integrated into the scene: a brass lamp with a tan shade in the top left, a brass lamp with a dark wood top in the middle right, and a brass lamp with a white shade in the bottom right.

2019 COLLECTION

www.brass-brothers.com
info@brass-brothers.com
T +39 055 229288
Bottega: Via Senese 50r
Showroom: Via Romana 151r
Firenze, Italia

Facebook: [brassbrothers](https://www.facebook.com/brassbrothers)
Skype: [brassbrothers](https://www.skype.com/brassbrothers)

by Il Bronzetto

